

# System 450™ Series Control Modules with Relay Outputs

## Installation Instructions

C450CBN-1  
C450CCN-1

Part No. 24-7664-2675, Rev. F  
Issued December 21, 2009  
Supersedes November 18, 2009

### Application

**IMPORTANT:** Use this System 450 Series Control Module with Relay Output only as an operating control. Where failure or malfunction of the System 450 control module could lead to personal injury or property damage to the controlled equipment or other property, additional precautions must be designed into the control system. Incorporate and maintain other devices, such as supervisory or alarm systems or safety or limit controls, intended to warn of or protect against failure or malfunction of the System 450 control module.

The System 450 Series is a family of modular, digital electronic controls that is easily assembled and set up to provide reliable temperature, pressure, and humidity control for a wide variety of Heating, Air Conditioning, Ventilation, and Refrigeration (HVACR) and commercial/industrial process applications.

The System 450 Series allows you to configure custom application-specific control systems with up to three input sensors and ten (relay and/or analog) outputs, including control systems that can monitor and control temperature, pressure, and humidity applications simultaneously.

You can easily install and quickly configure a stand-alone System 450 control module and sensor in the field as a replacement control for almost any temperature, pressure, and humidity control.

C450CxN-1 models are Single-Pole, Double-Throw (SPDT) relay control modules with Liquid Crystal Display (LCD) and four-button touch pad User Interface (UI) that allows you to set up a System 450 control system. C450CBN-1 models provide one SPDT relay, C450CCN-1 models provide two SPDT relays.

Refer to the *System 450 Series Technical Bulletin (LIT-12011459)* for more detailed information on designing, installing, setting up, and troubleshooting System 450 Series control systems. The System 450 technical bulletin can be accessed and downloaded on the Johnson Controls® Online Product Literature Web site at the following Web address:  
<http://cgproducts.johnsoncontrols.com/default.aspx>

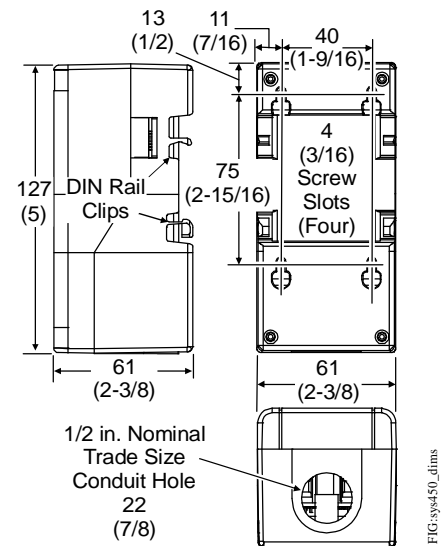

Figure 1: System 450 Module Dimensions

### Mounting

#### Location Considerations

Observe the following System 450 location guidelines:

- Ensure that the mounting surface can support the module assembly, mounting hardware, and any (user-supplied) panel or enclosure.
- Mount the modules in upright and plugged together in a horizontal row where possible. DIN rail mounting is highly recommended.
- Mount modules on flat even surfaces.
- Allow sufficient space for wires and connections.
- Mount the modules in locations free of corrosive vapors and observe the ambient operating conditions in the *Technical Specifications*.
- Do not mount the modules on surfaces that are prone to vibration or in locations where radio frequency or electromagnetic emissions may cause interference.
- Do not install the modules in airtight enclosures.
- Do not install heat-generating devices in an enclosure with the modules that may cause the temperature to exceed the ambient operating limit.

## Mounting System 450 Modules

Mount System 450 modules on 35 mm DIN rail (recommended) or directly to an even wall surface. To mount the modules on DIN rail:

1. Provide a section of 35 mm DIN rail that is longer than the module assembly width, and mount the DIN rail horizontally in a suitable location using appropriate mounting hardware/fasteners.
2. Clip the control module on the rail, position the upper DIN rail clips on the top rail, and gently snap the lower clips on to the rail.
3. Clip the remaining modules to the right of the control module on to the DIN rail and plug together.

To mount modules directly to wall surfaces:

1. Plug the modules together, remove the module covers, place the assembly against wall surface horizontally in a suitable location and mark the mount hole locations on the surface.
2. Install appropriate screw fasteners, leaving screw heads approximately one to two turns away from flush to the surface.
3. Place the assembly over screw heads and on the mounting slots, and carefully tighten mount screws.

**Note:** If you mount the modules on an uneven surface, do not damage the housings when tightening mounting screws. Use shims/washers to mount module assembly evenly on the surface.

Refer to the control sensor installation instructions for information on locating and mounting control sensors.

## Wiring

See Figure 2 and Table 1 for electrical termination locations and wiring information. See [Technical Specifications](#) on page 12 for electrical ratings.



### **WARNING: Risk of Electric Shock.**

Disconnect or isolate all power supplies before making electrical connections. More than one disconnect or isolation may be required to completely de-energize equipment. Contact with components carrying hazardous voltage can cause electric shock and may result in severe personal injury or death.

**IMPORTANT:** Use copper conductors only. Make all wiring in accordance with local, national, and regional regulations.

**IMPORTANT:** Do not exceed the System 450 module electrical ratings. Exceeding module electrical ratings can result in permanent damage to the modules and void any warranty.

**IMPORTANT:** Do not connect 24 VAC supply power to the System 450 modules before finishing wiring and checking all wiring connections. Short circuits or improperly connected wires can result in damage to the modules and void any warranty.

**IMPORTANT:** Run all low-voltage wiring and cables separate from all high-voltage wiring. Shielded cable is strongly recommended for input and output cables that are exposed to high electromagnetic or radio frequency noise.

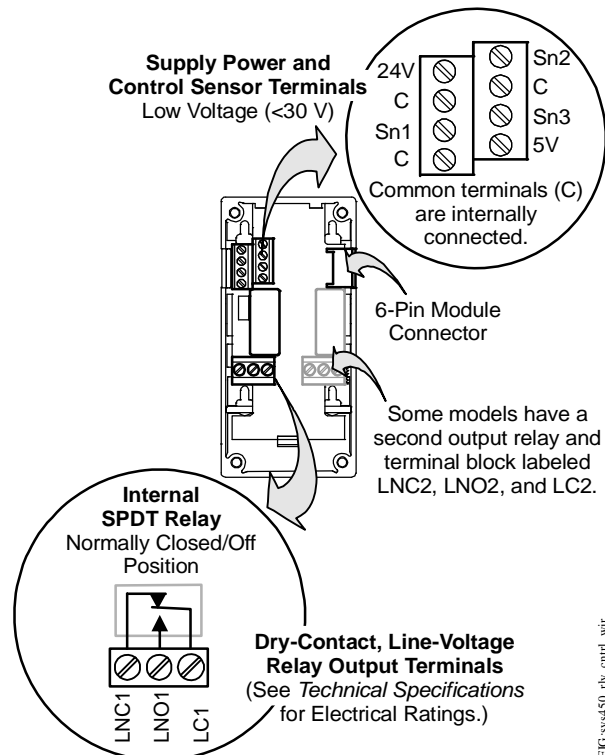

**Note:** The relay output terminals connect to an internal SPDT relay and do **not** supply any power to the application.

**Figure 2: C450CxN-1 Wiring Terminals**

FIG:sys450\_rly\_cmtL\_wir

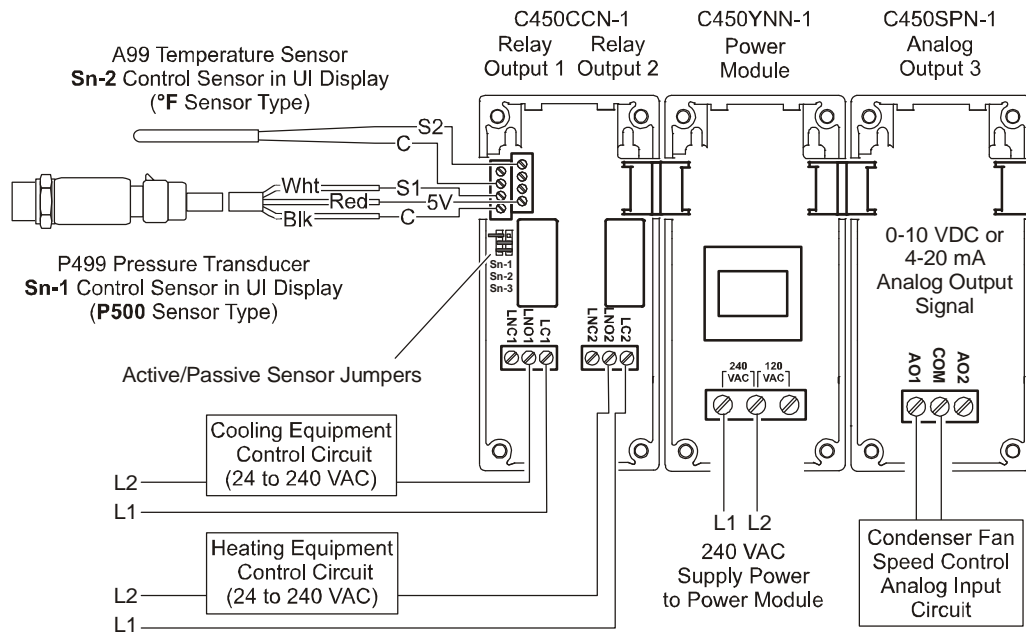

**Note:** In 120 VAC applications, L1 must be the Hot lead and L2 must be the Neutral/Common lead.

**Figure 3: Example System 450 Heat/Cool System with Condenser Fan Speed Control**

**Table 1: System 450 Terminal Wiring Information**

Label	Terminal Function	Wire Sizes
<b>24V</b>	Accepts 24 VAC supply power, when a C450YNN power module is <b>not</b> connected, and provides power terminal for 24 VAC (humidity) sensors.	0.08 mm <sup>2</sup> to 1.5 mm <sup>2</sup> 28 AWG to 16 AWG
<b>5V</b>	Provides 5 VDC power for active sensors.	
<b>S1, S2, S3</b>	Accepts passive or active (0-5 VDC) input signals from control sensors.	
<b>C</b> (Three Terminals)	Provide low-voltage Common connections for 24 VAC power and passive or active sensors connected to the 5V, Sn1, Sn2, and Sn3 terminals. <b>Note:</b> The three <b>C</b> terminals are connected internally and can be connected to ground in the field.	
<b>LNC1, LNC2</b>	Connects control circuit to the Normally Close (NC) contact on the SPDT relay.	0.08 mm <sup>2</sup> to 2.5 mm <sup>2</sup> 28 AWG to 14 AWG
<b>LNO1, LNO2</b>	Connects control circuit to the Normally Open (NO) contact on the SPDT relay.	
<b>LC1, LC2</b>	Connects line (power) to Common (C) on the SPDT relay.	

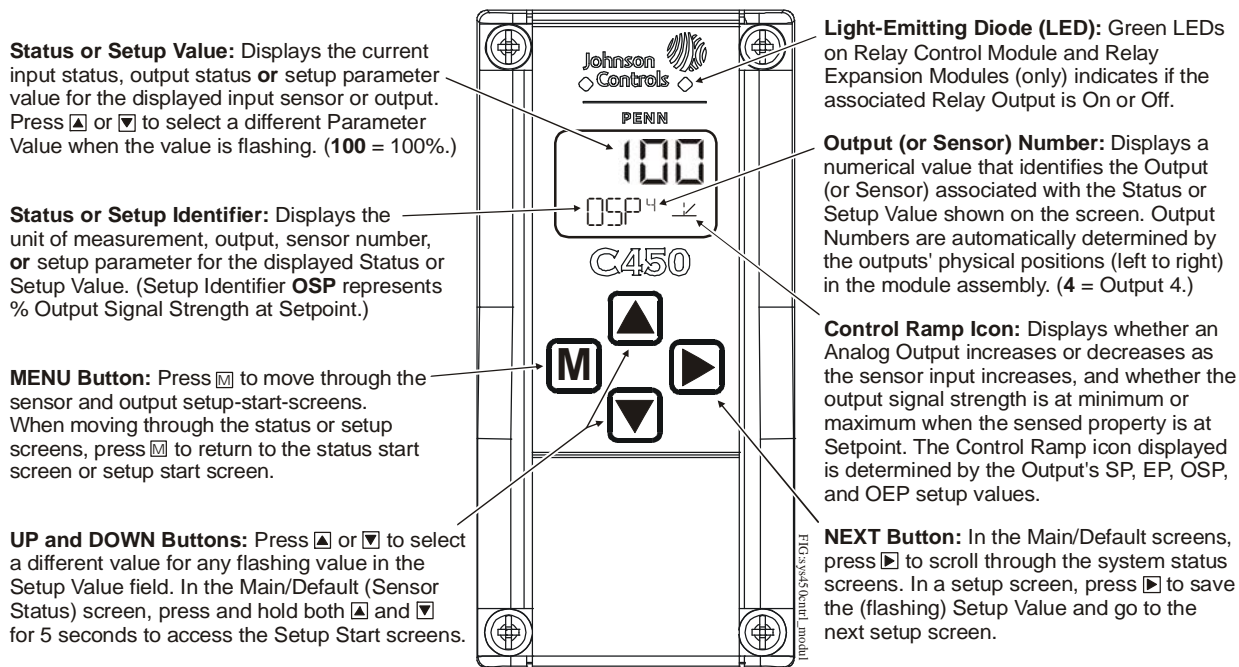

**Figure 4: System 450 Control Module Output Relay LEDs, LCD, Four-Button Touch Pad User Interface**

## Setup and Adjustments

### System 450 Component Requirements

A System 450 control system consists of one control module, one to three control sensor inputs, and one to ten outputs that provide On/Off control and/or analog control.

Figure 3 shows an example System 450 module assembly with two input sensors and three outputs (two relay outputs and one analog output).

### Building a System 450 Module Assembly

To build a System 450 module assembly:

1. Determine the controlled conditions, sensor types, and value ranges required for your application, and select the appropriate System 450 sensor types. See Table 3 for a list of System 450 sensors.
2. Determine the number and type (relay or analog) of outputs required to control your application, and select the appropriate System 450 control module and expansion modules to provide the outputs.
3. Assemble the control, power, and expansion modules in the proper order, starting with the control module on the left.

**Note:** The C450YNN-1 power module must be plugged directly into the control module. Plug the remaining expansion modules in the assembly to the right of the power module in any order.

4. Connect power to the module assembly.

You can now set up the inputs (sensors) and outputs for the module assembly in the control module's UI.

**Note:** A control system's inputs and outputs can be completely set up in the System 450 UI before you install and wire the module assembly.

### Setting up a Control System in the UI

System 450 control modules have a back-lit LCD and a four-button touch pad User Interface (UI) that enable you to set up the all of the inputs (sensors) and outputs in the module assembly (Figure 4).

Figure 7 provides an example System 450 setup overview that corresponds to the control system example shown in Figure 3 and the following setup examples and procedures.

To set up a control system in the System 450 UI:

1. Build your control system module assembly and connect it to power. See [Building a System 450 Module Assembly](#) on page 4.

**IMPORTANT:** Each time a module assembly is powered ON, the control module polls all of the modules to identify output type (relay or analog) and assigns a sequential output number (1 to 9 [0 = 10]) to each output starting with the control module output on the left. The output numbers identify each output's setup screens in the UI. (See Figure 4.)

2. Access the System 450 setup screens in the UI. See [Accessing the System 450 Setup Screens](#) on page 5.
3. Set up the control system inputs in the UI. See [Setting up System 450 Sensors](#) on page 6.
4. Set up the control system outputs in the UI. See [Setting up System 450 Outputs](#) on page 7.

**IMPORTANT:** Do not change the module positions after a System 450 control system is set up in the System 450 UI. System 450 control logic is set up in the UI according to the input Sensor Types, the output types, and the output numbers. Changing modules or module positions in a module assembly that is already set up in the UI, can change the output numbers, output types, and/or the setup values of the assembly outputs, which will require setting up the outputs again.

Use the worksheet provided on page 14 to plan and record the settings for your System 450 control system.

### Viewing the Main and System Status Screens

After your control system is installed, wired, and setup, the Main (Input Status) screen appears when you connect power to your system. During normal operation, the Main screen displays the current status of each input (sensor) in your control system. See Table 2 for more information about the Main screens.

The System Status screens can display an output status screen for each output in your control system along with the Input Status screens; in the Main (Input Status) screen, press NEXT repeatedly to scroll through and view all of the Output Status screens in your control system. See Table 2 for more information about the System Status screens.

**Table 2: System 450 Main Screens and Status Screens Information and Procedures**

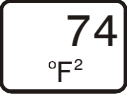
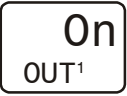
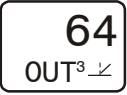
LCD Screen	Name, Description/Function, User Action, and Example
 	<p><b>Main (Input Status) Screen:</b> During normal operation, the Main screen automatically scrolls through the current status at each input sensor in your control system and displays the sensor number, the unit of measurement, and the sensed condition value. See Figure 7.</p> <p><b>Note:</b> Main screens are view-only, selections are not made in Main screens.</p> <p><b>Press NEXT repeatedly to scroll through and view the System Status screens for all inputs and outputs in your control system.</b></p> <p><b>Press and hold both UP and DOWN for 5 seconds to access your control system's setup screens.</b></p> <p><b>Note:</b> In any system setup screen, you can return to the Main Screens by pressing both UP and DOWN simultaneously. Also, the UI returns to the Main screen after 2 minutes of inactivity in any screen.</p> <p>Examples show Sensor 1 sensing <b>232 psi</b> and Sensor 2 sensing <b>74°F</b>.</p>
 	<p><b>System Status Screens:</b> The System Status screens display current status of all inputs <b>and</b> outputs in your control system. Relay output status screens display output number and relay status (On/Off). Analog output status screens display output number, signal strength, and control ramp icon. See Figure 7.</p> <p><b>Note:</b> System Status screens are view-only, selections are not made in Status screens.</p> <p><b>Press NEXT repeatedly to scroll and view the System Status screens for the inputs and outputs in your control system.</b></p> <p>Examples show <b>Output 1</b> relay is <b>On</b> and <b>Output 3</b> signal strength is <b>64%</b> of the total signal strength. The control ramp icon in the bottom screen example indicates that the Analog Output is set up with SP&lt;EP and OSP&lt;OEP. (See <a href="#">Setting up an Analog Output (OUTA#)</a> for information about control ramp icons.)</p>

### Accessing the System 450 Setup Screens

You can access the setup screens from the Main screen. To access the System 450 setup screens:

1. Apply power to your module assembly. After a start up check, the **Main** screen appears on the LCD.
2. In the **Main** screen, press and hold UP and DOWN simultaneously for 5 seconds to access the setup screens and to go to the **Sensor Setup Start** screen.

**Note:** The Sensor Setup Start screen is the first screen displayed when you access the System 450 setup screens. From the Sensor Setup Start screen, you can navigate to all of the remaining setup screens for your control system.

3. Press MENU repeatedly to scroll through the setup start screens. See Figure 7.

**Note:** The setup start screens are view-only; selections cannot be made in setup start screens. Press NEXT in a Setup Start screen to go to the sensor or output setup screens.

## Setting up System 450 Sensors

You must set up the input sensors for your control system before you can set up any of outputs. To set up the input sensors you must access the setup screens. See [Accessing the System 450 Setup Screens](#).

The Sensor Setup Start screen is the first screen displayed when you access the system setup screens in the System 450 UI.

Table 3 provides information about System 450 sensors, Sensor Types, parameter values, and specified sensor/transducer product code numbers.

Table 4 provides information, procedures, and examples regarding Sensor Setup screens and setting up sensors. Figure 7 provides a System 450 UI and setup overview example.

## Setting Active/Passive Sensor Jumpers

Before putting your System 450 control system into operation, you must set up each sensor in your system as either passive or active by positioning the jumper on the terminal pins on the terminal block, located below the sensor terminal block. See Figure 3.

Temperature sensors are passive (2-wire) sensors and the corresponding jumpers must be positioned across both pins. Humidity and pressure transducers are active (3-wire) sensors and corresponding jumpers must be positioned on one pin (or removed completely). See Figure 5 for the jumper positions for the System 450 example shown in Figure 3.

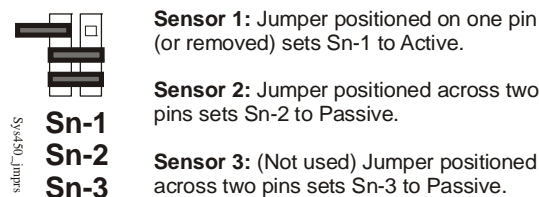

**Sensor 1:** Jumper positioned on one pin (or removed) sets Sn-1 to Active.

**Sensor 2:** Jumper positioned across two pins sets Sn-2 to Passive.

**Sensor 3:** (Not used) Jumper positioned across two pins sets Sn-3 to Passive.

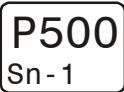
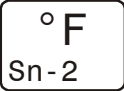
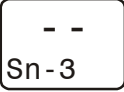

**Figure 5: Active/Passive Sensor Terminal Pin Block Set up for Example in Figure 3**

**Table 3: System 450 Sensor Types, Setup Values, and Sensor/Transducer Product Codes**

Sensor Type	Unit of Measurement Value (Condition/Units)	Effective Sensing Range	Range of Usable Values	Resolution Increment Value	Minimum Differential or Proportional Band	Sensor Product Type Number <sup>1</sup>
°F	°F (Temperature/degrees)	-46 to 255	-40 to 250	1	1	A99B-xxx
°C	°C (Temperature/degrees)	-43 to 124	-40 to 121	0.5	0.5	A99B-xxx
rH	% (Humidity/%RH)	1 to 100	10 to 95	1	2	HE67Sx-x
<b>P 05</b>	<b>INWC</b> (Pressure/in. W.C.)	0 to 0.5	0.025 to 0.5	0.005	0.025	DPT-2650-0R5D-AB
<b>P 8</b>	<b>bAR</b> (Pressure/bar)	-1 to 8	-1 to 8	0.05	0.1	P499Rxx-401C
<b>P 10</b>	<b>INWC</b> (Pressure/in. W.C.)	0 to 10	0.5 to 10	0.05	0.2	DPT-2650-010D-AB
<b>P 15</b>	<b>bAR</b> (Pressure/bar)	-1 to 15	-1 to 15	0.1	0.2	P499Rxx-402C
<b>P 30</b>	<b>bAR</b> (Pressure/bar)	0 to 30	0 to 30	0.1	0.4	P499Rxx-404C
<b>P 50</b>	<b>bAR</b> (Pressure/bar)	0 to 50	0 to 50	0.2	0.4	P499Rxx-405C
<b>P100</b>	<b>PSI</b> (Pressure/psi)	0 to 100	0 to 100	0.5	1	P499Rxx-101C
<b>P200</b>	<b>PSI</b> (Pressure/psi)	0 to 200	0 to 200	1	1	P499Rxx-102C
<b>P500</b>	<b>PSI</b> (Pressure/psi)	0 to 500	90 to 500	1	5	P499Rxx-105C
<b>P750</b>	<b>PSI</b> (Pressure/psi)	0 to 750	150 to 750	2	6	P499Rxx-107C

1. Refer to the *System 450 Series Modular Controls Product Bulletin (LIT-12011458)*, *Catalog Page (LIT-1900549)*, or *Technical Bulletin (LIT-12011459)* for complete ordering information for System 450 compatible sensors and transducers.

**Table 4: System 450 Sensor Setup Information and Procedures**

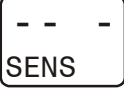
LCD Screen	Name, Description/Function, User Action, and Example
	<p><b>Sensor Setup Start Screen:</b> The Sensor Setup Start screen is the first screen displayed when you access the System 450 setup screens. From the Sensor Setup Start screen you can navigate to the Output Setup Start screens or the Sensor Setup screens. See Figure 7.</p> <p><b>Note:</b> You must setup the input sensors before you can setup the control system outputs. The Sensor Setup Start screen is view-only, selections are not made in setup start screens.</p> <p><b>Press MENU (repeatedly) to scroll through the Output Setup Start screens.</b> (See <i>Setting up a Relay Output (OUTR#)</i> and <i>Setting up an Analog Output (OUTA#)</i> for information and procedures on setting up outputs.)</p> <p><b>1. Press NEXT to go to the first Sensor Type Selection screen (Sn-1) and begin setting up the sensors in your control system.</b></p> <p>Example shows the Sensors Setup Start screen with four flashing dashes.</p>
  	<p><b>Sensor Type Selection Screens:</b> The Sensor Type you select for an input sensor automatically determines the setup parameters and values for each output that is set up to reference that sensor. See Table 3 for information about System 450 sensors/transducers, Sensor Types, condition type, units of measurement, minimum differential or proportional band, setup values, value ranges, and product code numbers.</p> <p><b>Note:</b> For an output to operate properly, the selected Sensor Type must match the sensor/transducer model wired to the control module, and the sensor/transducer must be wired to the proper control module input terminals.</p> <p><b>2. In the Sn-1 Sensor Type Selection screen, press UP or DOWN to select the desired Sensor Type. Press NEXT to save your selection and go to the Sn-2 Sensor Type Selection screen.</b></p> <p><b>3. In the Sn-2 Sensor Type Selection screen, press UP or DOWN to select the desired Sensor Type. Press NEXT to save your selection and go to the Sn-3 Sensor Type Selection screen.</b></p> <p><b>Note:</b> If your control system does not use three input sensors, simply press NEXT while the two dashes are flashing in a Sensor Type Selection screen to save <b>no</b> Sensor Type and go to the next setup screen.</p> <p><b>4. In the Sn-3 Sensor Type Selection screen, press UP or DOWN to select the desired Sensor Type. Press NEXT to save your selection and either:</b></p> <ul style="list-style-type: none"> <li>go to the Temperature Offset Setup screen for the first temperature sensor in your system.</li> <li>return to the Sensor Setup-Start Screen, if your control system has no temperature sensors.</li> </ul> <p>Examples show <b>Sensor 1</b> with the P500 Sensor Type selected; Sensor 2, with the °F Sensor Type selected; and Sensor 3, with the <b>no</b> Sensor Type selected.</p>
	<p><b>Temperature Offset Selection Screens:</b> Select a temperature offset for the temperature inputs (only) in your control system.</p> <p>Sensor Type °F enables an offset of +/- 5°F in 1 degree increments.          Sensor Type °C enables an offset of +/- 2.5°C in 0.5 degree increments.</p> <p><b>Note:</b> The temperature offset changes the displayed temperature value by the selected offset value.</p> <p><b>5. Press UP or DOWN to select the desired temperature offset value. Press NEXT:</b></p> <ul style="list-style-type: none"> <li>to go to the next Temperature Offset Selection screen and repeat this step (if required).</li> <li>to return to the Sensors Setup-Start Screen.</li> </ul> <p>Example shows -3 (flashing) is the selected temperature <b>offset</b> value for Sensor 2, thus a sensed temperature of 75°F at Sensor 2 is displayed as 72°F.</p>
	<p><b>Sensors Setup Start Screen:</b> The Sensor Setup screens return to the Sensor Setup Start screen.</p> <p><b>After the sensors are set up for your control system, you can:</b></p> <ul style="list-style-type: none"> <li>Press MENU to scroll through the Output Setup Start screens and begin setting up your system outputs. (See <i>Setting up a Relay Output (OUTR#)</i> and <i>Setting up an Analog Output (OUTA#)</i> for more information and procedures.)</li> <li>Press UP and DOWN simultaneously and hold for 5 seconds to return to the Main screens.</li> </ul> <p>Example shows Input Sensors Setup-Start screen with four flashing dashes.</p>

**Setting up System 450 Outputs**

After you build and connect power to your control system module assembly, the output numbers and output types for your control system are automatically assigned in the UI.

**Note:** You must set up the input sensors for your control system before you can set up the outputs.

To set up System 450 outputs in the UI:

1. Access the System 450 setup screens, the **Sensor Setup Start** screen (**SENS**) appears. (See [Accessing the System 450 Setup Screens](#).)
2. In the **Sensor Setup Start** screen (**SENS**), press MENU repeatedly to scroll through and select the desired **Output Setup Start** screen. The Output Setup Start screen indicates the output number and the output type for the selected output.





For Relay Outputs, see [Setting up a Relay Output \(OUTR#\)](#) and Table 5 for setup information and procedures.

For Analog Outputs, see [Setting up an Analog Output \(OUTA#\)](#) and Table 7 for setup information and procedures.

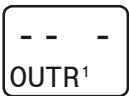
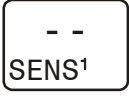
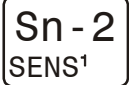

### Setting up a Relay Output (OUTR#)

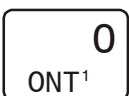
Relay outputs provide On/Off control for the equipment in your application based on input from the sensor the output is set up to reference. See Table 5 for relay output setup information and procedures.

**Table 5: System 450 Relay Output Setup Screen Information, and User Actions**

LCD Screen	Name, Description/Function, User Action, and Example
	<p><b>Relay Output Setup Start Screen:</b> Output number and the output type (relay or analog) are automatically assigned when you connect power to your control system's module assembly.</p> <p><b>Note:</b> You must set up the system's sensors before you can set up the outputs.</p> <p><b>1. Press NEXT to go to this output's Sensor Selection screen.</b></p> <p>Example shows the Relay Output Setup-Start screen for Output 1.</p>
 	<p><b>Sensor Selection Screen:</b> The sensor you select here determines this output's setup parameters and values, including condition type, unit of measurement, minimum differential, default setup values, and setup value ranges for several of the remaining output setup screens. If a sensor is not selected here, this output's remaining setup screens do not appear. If a sensor is already selected for this output, the Sensor Selection screen does not appear here, instead the Relay ON Selection screen appears.</p> <p><b>Note:</b> You must select a sensor in this Sensor Selection screen <b>and</b> the selected sensor must be already set up in the System 450 UI. (See <a href="#">Setting up System 450 Sensors</a>.)</p> <p><b>2. Press UP or DOWN to select the Sensor (Sn-1, Sn-2, or Sn-3) that this output references. Press NEXT to save your sensor selection and go to the Relay ON Selection Screen.</b></p> <p>Example shows input Sensor 2 selected for Output 1.</p>
	<p><b>Relay ON Selection Screen:</b> Select the value at which the relay turns On. Relay <b>ON</b> is defined as relay LED On/Lit, relay contacts NO to C are closed, and NC to C contacts are open.</p> <p><b>Note:</b> The value ranges and minimum differential are determined by the Sensor Type selected for the sensor that this output references and are enforced in the Relay ON and Relay OFF Selection screens.</p> <p><b>3. Press UP or DOWN to select the value at which the output relay turns On. Press NEXT to save your selection and go to Relay OFF Selection Screen.</b></p> <p>Example shows an ON value of 78 (°F) selected for Relay Output 1.</p>
	<p><b>Relay OFF Selection Screen:</b> Select the value at which the relay turns Off. Relay <b>OFF</b> is defined as relay LED Off, relay contacts NC to C are closed, and NO to C contacts are open.</p> <p><b>Note:</b> The value ranges and minimum differential are determined by the Sensor Type selected for the sensor that this output references and are enforced in the Relay ON and Relay OFF Selection screens.</p> <p><b>4. Press UP or DOWN to select the value at which output relay turns Off. Press NEXT to save your selection and go to Minimum Relay ON Time Selection Screen.</b></p> <p>Example shows an OFF value of 75 (°F) selected for Relay Output 1.</p>
	<p><b>Minimum Relay ON Time Selection Screen:</b> Minimum ON Time range is <b>0</b> to <b>300</b> seconds.</p> <p><b>5. Press UP or DOWN to select the minimum time that the output relay remains On after reaching the Relay ON value. Press NEXT to save your selection and go to the Minimum Relay OFF Time Selection Screen.</b></p> <p>Example shows 0 (zero) seconds selected for the minimum ON-Time for Output 1.</p>
	<p><b>Minimum Relay OFF Time Selection Screen:</b> Minimum OFF Time range is <b>0</b> to <b>300</b> seconds.</p> <p><b>6. Press UP or DOWN to select the minimum time that this output relay remains Off after reaching the Relay OFF value. Press NEXT to save your selection and go to the Sensor Failure Mode Selection screen.</b></p> <p>Example shows 120 seconds selected for the minimum OFF-Time for Output 1.</p>

**Table 5: System 450 Relay Output Setup Screen Information, and User Actions (Continued)**

LCD Screen	Name, Description/Function, User Action, and Example
	<p><b>Sensor Failure Mode Selection Screen:</b> Select this output's mode of operation if the referenced sensor or sensor wiring fails. The output operates in the selected mode until the failure is remedied. Sensor Failure mode selections for Relay Outputs include:</p> <ul style="list-style-type: none"> <li>• <b>ON</b> output relay remains On during sensor failure.</li> <li>• <b>OFF</b> output relay remains Off during sensor failure.</li> </ul> <p><b>7. Press UP or DOWN to select this output mode of operation if the sensor or sensor wiring fails. Press NEXT to save your sensor failure mode selection and go to the Edit Sensor Screen.</b></p> <p>Example shows OFF sensor failure mode selected for Output 1. This output relay is Off if the referenced sensor or sensor wiring fails.</p>
	<p><b>Edit Sensor Screen:</b> This screen displays the sensor that this output currently references. Typically, no action is taken in this screen. But if you can need to change the sensor that this output references, you can select a different sensor for this output in this screen.</p> <p><b>Note:</b> Changing the sensor that an output references to a sensor with a different Sensor Type changes the default setup values for the output, and requires setting up the output again.</p> <p><b>8. To change this output's sensor, Press UP or DOWN to select the sensor that this output will reference. After you select a different sensor for this output, press NEXT to return to the Relay ON Selection screen (Step 3 above) and repeat the output relay setup procedure for this output and the new Sensor Type values associated with the new sensor selection.</b></p> <p><b>If you do not need to change this output's sensor, simply press NEXT to save the current sensor selection and return to the Relay Output Setup Start screen.</b></p> <p>This Relay Output is now set up in the System 450 UI. Example shows input Sensor 2 selected for Output 1 (Output 1 references Sensor 2).</p>
	<p><b>Relay Output Setup Start Screen</b></p> <p>After you have set up this Relay Output, you can go to another Output Setup Start screen, the Sensor Setup Start screen, or return to the Main screens.</p> <p><b>9. Press MENU to scroll through the remaining Output Setup Start screens and return to the Sensor Setup Start screen, or press UP and DOWN simultaneously and hold for 5 seconds to return to the System 450 Main screens.</b></p> <p>Example shows the Relay Output Setup-Start screen for Output 1.</p>

**Setting up an Analog Output (OUTA#)**

Analog outputs provide an auto-selecting analog signal that is proportional to the sensed input condition. The analog output circuit senses the impedance and automatically selects 0-10 VDC or 4-20 mA operation.

The control action between the input signal and the output signal can be set up four different ways, depending on the values selected for the Setpoint (SP), End Point (EP), %Output Signal Strength at Setpoint (OSP), and %Output Signal Strength at End Point (OEP). The LCD displays different Control Ramp icons for the four control actions.

Figure 6 shows an example of the analog output setup values and the resulting output signal in a typical space heating application (SP > EP and OSP < OEP).



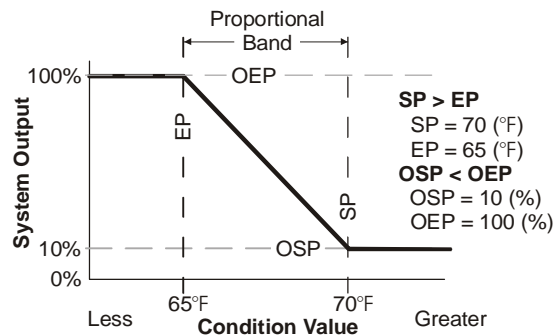

Table 6 shows the four Control Ramp icons and the associated analog output setup value relationships.







**Figure 6: Control Ramp Example for a Typical Heating Application (SP > EP and OSP < OEP)**

See Table 7 for analog output setup information and procedures.



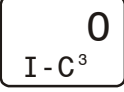

**Table 6: Analog Output Control Ramp Icons**

Control Ramp Displayed on LCD	Analog Output Value Relationships	Output Signal Strength at Setpoint
	SP < EP OSP < OEP	Minimum
	SP > EP OSP < OEP	Minimum
	SP > EP OSP > OEP	Maximum
	SP < EP OSP > OEP	Maximum

**Table 7: System 450 Analog Output Setup Screens Information (Part 1 of 2)**

LCD Screen	Name, Description/Function, User Action, Example
	<p><b>Analog Output Setup Start Screen:</b> Output number and the output type (relay or analog) are automatically assigned when you connect power to your control system's module assembly.</p> <p><b>Note:</b> You must set up the system's sensors before you can set up the outputs.</p> <p><b>1. Press NEXT to go to this output's Sensor Selection screen.</b></p> <p>Example shows the Analog Output Setup-Start screen for Output 3.</p>
	<p><b>Sensor Selection Screen:</b> The Sensor you select here determines this output's setup parameters and values, including condition type, unit of measurement, minimum proportional band, default setup values, and setup value ranges for several of the remaining output setup screens. If a sensor is not selected here, this output's remaining setup screens do not appear. If a sensor is already selected for this output, the Sensor Selection screen does not appear here, instead the Setpoint Selection screen appears.</p> <p><b>Note:</b> You must select a sensor in this Sensor Selection screen <b>and</b> the selected sensor must be already set up in the System 450 UI. (See <i>Setting up System 450 Sensors.</i>)</p> <p><b>2. Press UP or DOWN to select the Sensor (Sn-1, Sn-2, or Sn-3) that this output references. Press NEXT to save your sensor selection and go to the Setpoint Selection screen.</b></p> <p>Example shows input Sensor 1 (Sn-1) selected for Output 3.</p>
	<p><b>Setpoint Selection Screen:</b> Setpoint is the target value that the controlled system drives towards and along with End Point, defines this output's proportional band.</p> <p><b>Note:</b> An output's minimum proportional band (between Setpoint and End Point) is automatically enforced in the output's Setpoint and End Point Selection screens.</p> <p><b>3. Press UP or DOWN to select this output's Setpoint value. Press NEXT to save your Setpoint value selection and go to the End Point Selection screen.</b></p> <p>Example shows a <b>Setpoint</b> of 200 (psi) selected for Output 3.</p>
	<p><b>End Point Selection Screen:</b> End Point is the (condition) value that the controlled system drives away from (towards Setpoint) and, along with Setpoint, defines this output's proportional band.</p> <p><b>Note:</b> An output's proportional band (between Setpoint and End Point) is automatically enforced in the output's Setpoint and End Point Selection screens.</p> <p><b>4. Press UP or DOWN to select this output's End Point value. Press NEXT to save your End Point value selection and go to the %Output Signal Strength at Setpoint Selection screen.</b></p> <p>Example shows a <b>End Point</b> of 250 (psi) selected for Output 3.</p>

**Table 7: System 450 Analog Output Setup Screens Information (Part 2 of 2)**

LCD Screen	Name, Description/Function, User Action, Example
	<p><b>Output Signal Strength at Setpoint Selection Screen:</b> Select the strength of the signal that this output generates when the sensed condition is at the Setpoint value. The signal strength range is <b>0 to 100 (%)</b>.</p> <p><b>5. Press UP or DOWN to select this output's %Output Signal Strength at Setpoint value. Press NEXT to save your selection and go to the %Output Signal Strength at End Point Selection screen.</b></p> <p>Example shows Analog Output <b>3</b> is setup to generate <b>10%</b> of the total signal strength when the input is at the Setpoint value (= 1 V or 5.6 mA).</p>
	<p><b>Output Signal Strength at End Point Selection Screen:</b> Select the strength of the signal that this output generates when the sensed condition is at the End Point value. The signal strength range is <b>0 to 100 (%)</b>.</p> <p><b>6. Press UP or DOWN to select this output's %Output Signal Strength at End Point value. Press NEXT to save your selection and go to the Integration Constant Selection screen.</b></p> <p>Example shows Output <b>3</b> is set up to generate <b>90%</b> of the total signal strength when the input is at the End Point value (= 9 V or 18.4 mA).</p>
	<p><b>Integration Constant Selection Screen:</b> An integration constant allows you to set up proportional plus integral control for this analog output. proportional plus integral control can drive the load closer to Setpoint than proportional only control.</p> <p><b>Note:</b> Initially, you should select the I-C value of <b>0</b> (zero) for no integration constant. Refer to the <i>System 450 Series Technical Bulletin (LIT-12011459)</i> for more information on proportional plus integral control and setting an integration constant in the System 450 UI.</p> <p><b>7. Press UP or DOWN to select this output's Integration Constant for proportional plus integral control. Press NEXT to save your selection and go to the Sensor Failure Mode Selection screen.</b></p> <p>Example shows an <b>Integration Constant of 0</b> (zero) selected for Output <b>3</b>.</p>
	<p><b>Sensor Failure Mode Selection Screen:</b></p> <p><b>8. Press UP or DOWN to select this output's mode of operation if the sensor or sensor wiring fails. Press NEXT to save your selection and go to the Edit Sensor Selection screen.</b></p> <p>You can select this output's mode of operation in the event of a sensor or sensor wiring failure. The output operates in the selected mode until the failure is fixed. Sensor Failure Mode selections for Analog Outputs include:</p> <ul style="list-style-type: none"> <li>• <b>ON</b> - output generates maximum signal strength during sensor failure.</li> <li>• <b>OFF</b> - output generates minimum signal strength during sensor failure.</li> </ul> <p>Example shows the <b>OFF</b> Sensor Failure Mode selected for Output <b>3</b>.</p>
	<p><b>Edit Sensor Selection Screen:</b> Press Up or Down to change the sensor that this output references (only if required), then press Next to go to this output's setup start screen.</p> <p><b>Note:</b> Changing the sensor that an output references to a sensor with a different Sensor Type changes the default setup values for the output, and requires setting up the output again.</p> <p>Example shows input Sensor <b>1</b> selected for Output <b>3</b>.</p>

## Technical Specifications

### C450CxN-1

<b>Product</b>	C450CxN-1: System 450 Control Modules are sensing controls and operating controls with LCD, four-button touch pad, and On/Off relay output. C450CBN-1: Control Module with one SPDT output relay C450CCN-1: Control Module with two SPDT output relays									
<b>Supply Power</b>	C450YNN-1 Power Supply Module or 24 (20-30) VAC Safety Extra-Low Voltage (SELV) (Europe) Class 2 (North America) 50/60 Hz, 10 VA minimum									
<b>Ambient Operating Conditions</b>	<b>Temperature:</b> -40 to 66°C (-40 to 150°F) <b>Humidity:</b> Up to 95% RH noncondensing; Maximum Dew Point 29°C (85°F)									
<b>Ambient Shipping and Storage Conditions</b>	<b>Temperature:</b> -40 to 80°C (-40 to 176°F) <b>Humidity:</b> Up to 95% RH noncondensing; Maximum Dew Point 29°C (85°F)									
<b>Input Signal</b>	0-5 VDC; 1035 ohms at 25°C (77°F) for an A99 PTC Temperature Sensor									
<b>Output Relay Contacts</b>	<b>General:</b> 1/2 HP at 120/240 VAC, SPDT <b>Specific:</b> <table border="1" style="width: 100%; border-collapse: collapse;"> <thead> <tr> <th>AC Motor Ratings</th> <th>120 VAC</th> <th>208/240 VAC</th> </tr> </thead> <tbody> <tr> <td>AC Full-load Amperes:</td> <td>9.8 A</td> <td>4.9 A</td> </tr> <tr> <td>AC Locked-Rotor Amperes:</td> <td>58.8 A</td> <td>29.4 A</td> </tr> </tbody> </table> 10 Amperes AC Non-inductive at 24/240 VAC Pilot Duty: 125 VA at 24/240 VAC	AC Motor Ratings	120 VAC	208/240 VAC	AC Full-load Amperes:	9.8 A	4.9 A	AC Locked-Rotor Amperes:	58.8 A	29.4 A
AC Motor Ratings	120 VAC	208/240 VAC								
AC Full-load Amperes:	9.8 A	4.9 A								
AC Locked-Rotor Amperes:	58.8 A	29.4 A								
<b>Analog Input</b>	<b>Resolution:</b> 14 bit									
<b>Control Construction</b>	Independently-mounted control, surface mounted with Lexan® 950 enclosure suitable for DIN rail mounting or direct mounting to a hard, even surface.									
<b>Dimensions (H x W x D)</b>	127 x 61 x 61 mm (5 x 2-3/8 x 2-3/8 in.)									
<b>Weight</b>	C450CBN-1: 209 gm (0.46 lb) C450CCN-1: 222 gm (0.49 lb)									
<b>Compliance</b>	<b>North America:</b> cULus Listed; UL 60730, File E27734, Vol. 1; FCC Compliant to CFR47, Part 15, Subpart B, Class B Industry Canada (IC) Compliant to Canadian ICES-003, Class B limits <b>Europe:</b> Mark: CE Compliant; Low Voltage Directive (2006/95/EC); EMC Directive (2004/108/EC); RoHS Directive (2002/95/EC); WEEE Directive (2002/96/EC) <b>Australia:</b> Mark: C-Tick Compliant (N1813)									

The performance specifications are nominal and conform to acceptable industry standards. For application at conditions beyond these specifications, consult Johnson Controls Application Engineering at (414) 524-5535. Johnson Controls, Inc. shall not be liable for damages resulting from misapplication or misuse of its products.

#### United States Emissions Compliance

This equipment has been tested and found to comply with the limits for a Class B digital device, pursuant to Part 15 of the FCC Rules. These limits are designed to provide reasonable protection against harmful interference in a residential installation. This equipment generates, uses and can radiate radio frequency energy and, if not installed and used in accordance with the instructions, may cause harmful interference to radio communications. However, there is no guarantee that interference will not occur in a particular installation. If this equipment does cause harmful interference to radio or television reception, which can be determined by turning the equipment off and on, the user is encouraged to try to correct the interference by one or more of the following measures:

- Reorient or relocate the receiving antenna.
- Increase the separation between the equipment and receiver.
- Connect the equipment into an outlet on a circuit different from that to which the receiver is connected.
- Consult the dealer or an experienced radio/TV technician for help.

#### Canadian Emissions Compliance

This Class (B) digital apparatus meets all the requirements of the Canadian Interference-Causing Equipment Regulations.

Cet appareil numérique de la Classe (B) respecte toutes les exigences du Règlement sur le matériel brouilleur du Canada.

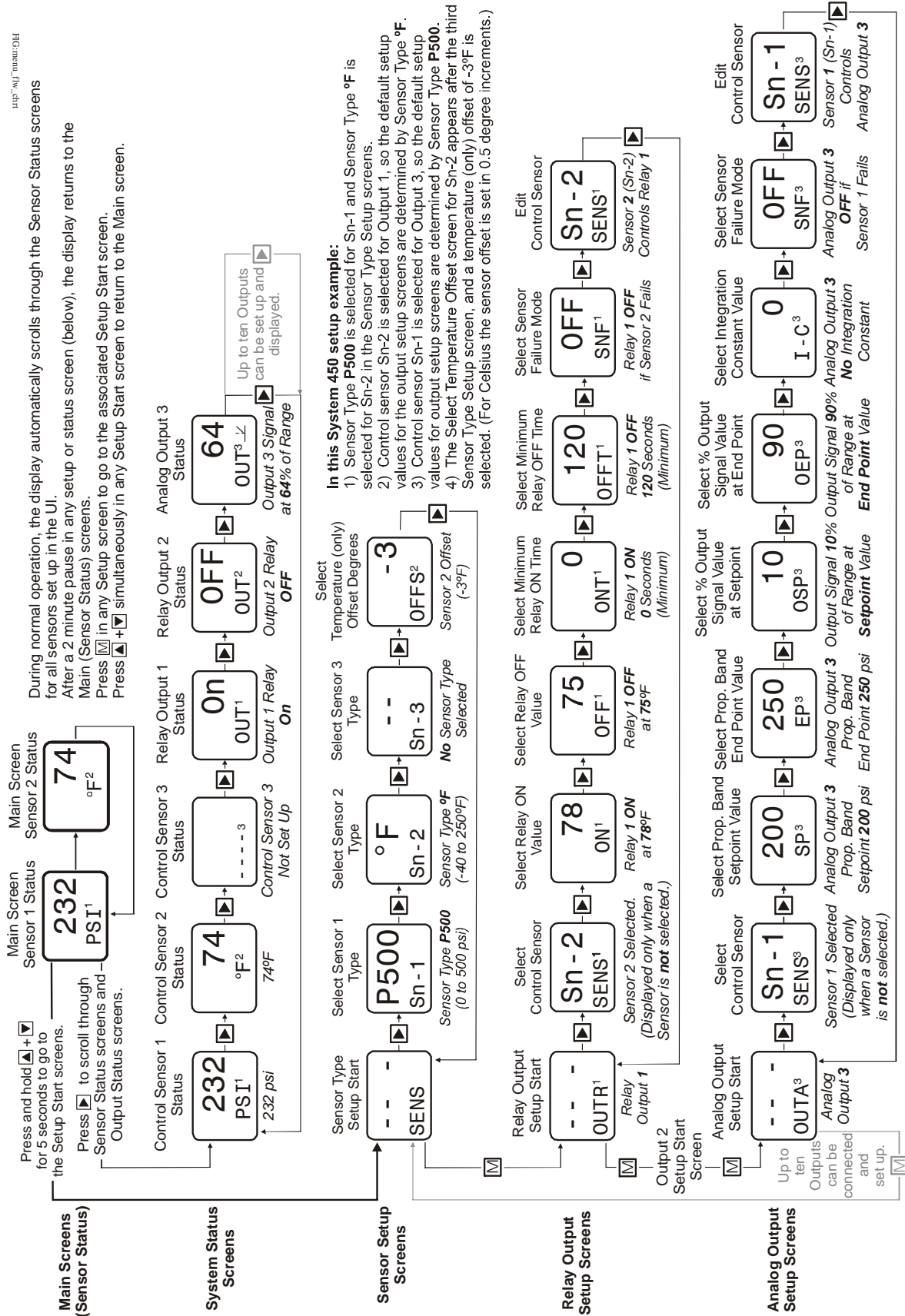

Figure 7: System 450 Status Screens, Setup Screens, and Menu Flow Example

System Location \_\_\_\_\_ System Name \_\_\_\_\_  
 Equipment Controlled \_\_\_\_\_ Serviced/Set up by \_\_\_\_\_ Phone \_\_\_\_\_

Sensors	Sensor Type	Control Range	Display Resolution	Minimum Differential	Offset (Temp. Sensors Only)
Example Sn-1	P500	90 to 500 (psi)	1 psi	5 psi	(N/A)
Example Sn-2	°F	-40 to 250 (°F)	1 °F	1 °F	0 (°F)
Sn-1					
Sn-2					
Sn-3					

Relay Output and/or Analog Output Setup Identifiers									
Output Number	OUTR# (Relay Output)	SENS# Sensor Type (Sensor Selection and Sensor Type)	ON# (Relay ON Value)	OFF# (Relay OFF Value)	ONT# (Minimum ON Time Value)	OFFT# (Maximum ON Time Value)	(No Selection Screen for Relay Output)	SNF# (Sensor Failure Mode of Operation)	
	OUTA# (Analog Output)	SP# (Setpoint Value)	EP# (Endpoint Value)	OSP# (% Output Signal at Setpoint)	OEP# (% Output Signal at Endpoint)	I-C# (Integration Constant)			
Example OUT 1	OUTR1	Sn-2/°F	78 (°F)	75 (°F)	0 (sec.)	120 (sec.)	(N/A)	OFF	
Example OUT 4	OUTA4	Sn-1/P500	200 (psi)	250 (psi)	10 (%)	90 (%)	0 (none)	OFF	
OUT 1									
OUT 2									
OUT 3									
OUT 4									
OUT 5									
OUT 6									
OUT 7									
OUT 8									
OUT 9									
OUT 10									





**Building Efficiency**  
507 E. Michigan Street, Milwaukee, WI 53202

*Metasys® and Johnson Controls® are registered trademarks of Johnson Controls, Inc.  
All other marks herein are the marks of their respective owners. © 2009 Johnson Controls, Inc.*